



Efficient Equipment Diagnosis

With Rion Products and Measurement Solutions



Measurement solutions for simple diagnosis

P.4

**Easy and quick measurement with a single button
Simply hold against the target object**

Pocketable Vibration Meter VM-63C

**Select from three measurement modes:
acceleration, velocity or displacement
Suitable for general applications**

General-Purpose Vibration Meter VM-82A

Measurement solutions for detailed diagnosis

P.5

**Simultaneous measurement of acceleration, velocity,
and displacement — FFT analysis also supported**

Vibration Analyzer VA-12

**Vibration meter mode and FFT analysis functionality,
along with simultaneous measurement up to four channels**

Vibration Analysis Program SX-A1VA

Simple diagnosis using dedicated equipment diagnosis program (Vibration Analysis Program SX-A1VA)

P.6-7

Measurement with absolute value evaluation

Simple diagnosis

Measurement with relative value evaluation

Trend management (relative value evaluation)

Constant monitoring and measurement solutions

P.8-9

Constant monitoring of machine vibrations at power stations, plants or other production facilities

Vibration Monitor UG-50

Support for round-the-clock vibration monitoring via USB or Ethernet interface

Vibration Meter Unit UV-15 / UV-22

Equipment diagnosis software
Equipment Diagnosis Software CAT-EQDIAG P.10

Other systems
Noise Monitoring System SY-117 P.11

Judgement Program SX-A1CMP /
Order Tracking Program CAT-SAA1-ORDTRK P.11

Piezoelectric accelerometers / Simulators P.12

Measurement solutions for simple diagnosis applications

— Optimal simple diagnosis tools —

Top priority: operation convenience and functionality. Low-cost model designed for holding against the measurement object.

Pocketable Vibration Meter VM-63C

- Simply by holding the unit against the target object, measurement over a wide range of vibration frequencies is possible.
- LCD readout shows either acceleration (m/s^2 EQ Peak), velocity (mm/s RMS), or displacement (mm EQ P-P).
- Measurement to determine unbalanced conditions, misalignment (low vibration frequency range) or bearing vibrations (high vibration frequency range) is also possible.

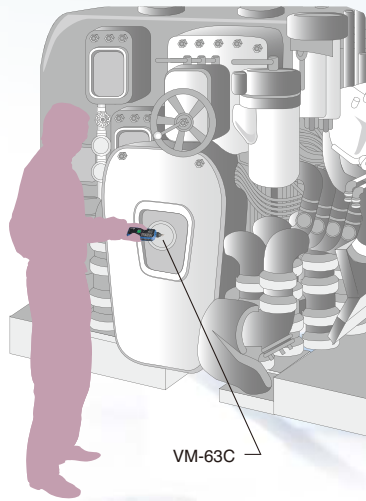

VM-63C

Select from three measurement modes: acceleration, velocity or displacement. Suitable for general applications.

General-Purpose Vibration Meter VM-82A

- Designed mainly for maintenance and inspection of industrial machinery, with particular focus on rotational machinery.
- Backup function instantly reactivates previous settings at next power-on.
- Convenient USB interface allows transfer of saved data to a computer.



Piezoelectric accelerometer (with integrated amplifier) PV-571

Magnet attachment (supplied)

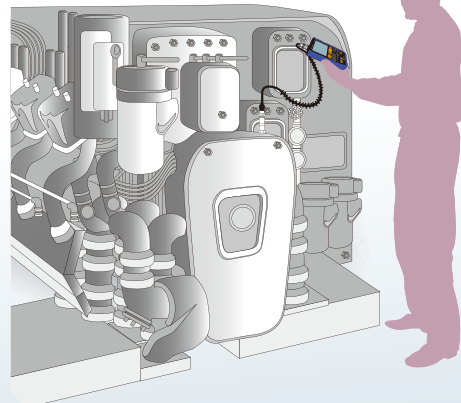

Measurement solutions for detailed diagnosis applications

— Optimal tools for in-depth diagnosis —

Simultaneous measurement of acceleration, velocity, and displacement. Also supports FFT analysis.

Vibration Analyzer VA-12

- Designed for hand-held use in the field, comprising analysis functions suitable for equipment diagnosis and on-site measurements.
- Supports vibration magnitude measurement for simple diagnosis, as well as detailed diagnosis for example to determine the cause of a fault or assess the failure stage and location.

Vibration meter mode

- Enables simultaneous measurement of acceleration, velocity, and displacement as well as crest factor.

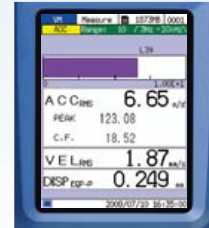

Vibration meter mode

FFT mode

- Real-time analysis frequency 20 kHz
- Time waveform and spectrum display. Frequency analysis with up to 3200 spectrum lines. Envelope processing for bearing diagnosis also supported.
- Vibration waveform recording capability

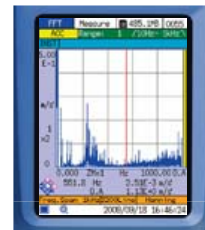

Spectrum (3200 lines)

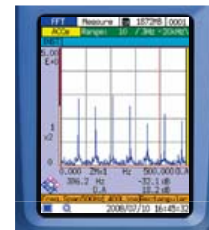

Spectrum after envelope processing

Piezoelectric accelerometer (with integrated amplifier) PV-571
Magnet attachment (supplied)

Vibration meter mode and FFT analysis functionality, along with simultaneous measurement up to four channels

Vibration Analysis Program SX-A1VA

(for RIONOTE Multifunction Measurement System)

- All essential basic vibration measurement functions are provided, enabling equipment diagnosis and vibration monitoring for industrial machinery.
- Auto store function continuously records vibration values and tacho data in 100 ms intervals.
- Supports detailed diagnosis using FFT analysis and envelope processing functions. ISO compliant absolute value evaluation can also be performed.
- Connection of up to four accelerometers makes it possible to realize simultaneous measurement in two horizontal directions and one vertical direction, as well as other multi-plane measurements.



Vibration meter mode



Simple diagnosis



Detailed diagnosis (bearing)

Simple diagnosis using dedicated equipment diagnosis program

(Vibration Analysis Program SX-A1VA)

The SX-A1VA program adds vibration measurement functions to the RIONOTE Multifunction Measurement System.

Measurement with absolute value evaluation

Simple diagnosis

By periodically measuring the vibration magnitude and comparing the results to a reference value, the equipment condition (normal or potential problem) can be diagnosed.

The example at right shows the screen in absolute value measurement mode for four channels.

As a danger state indicated by purple-red, caution by yellow, and good by green, the display of measurement results lets the operator assess the state of vibration at a glance.



Absolute value evaluation mode (absolute value evaluation function)

ISO 10816 series (Evaluation of machine vibration by measurements on non-rotating parts).

According to ISO 10816-1:1995 / Amd. 1:2009, evaluation criteria for mechanical vibration over a specified range are to be decided by agreement between the supplier and the user of the machine, and boundary values for evaluation are to be determined in consideration of the measurement position and the support rigidity of the machine etc.

Evaluation reference value

- A: Newly installed machinery will normally be within this range.
- B: Long-term continuous operation allowed.
- C: Long-term continuous operation not allowed, but limited-term operation allowed.
- D: High risk of injury. Operation not allowed.

Representative zone boundary value

Vibration velocity rms value mm/s	Range of representative zone boundary value		
0.28	Zone boundary value A/B 0.71 to 4.5	Zone boundary value B/C 1.8 to 9.3	Zone boundary value C/D 4.5 to 14.7
0.45			
0.71			
1.12			
1.8			
2.8			
4.5			
7.1			
9.3			
11.2			
14.7			
18			
28			
45			



Standard mode (evaluation function)

Two threshold values (upper and lower each) are set for acceleration, velocity, and displacement to perform evaluation.

Connection examples

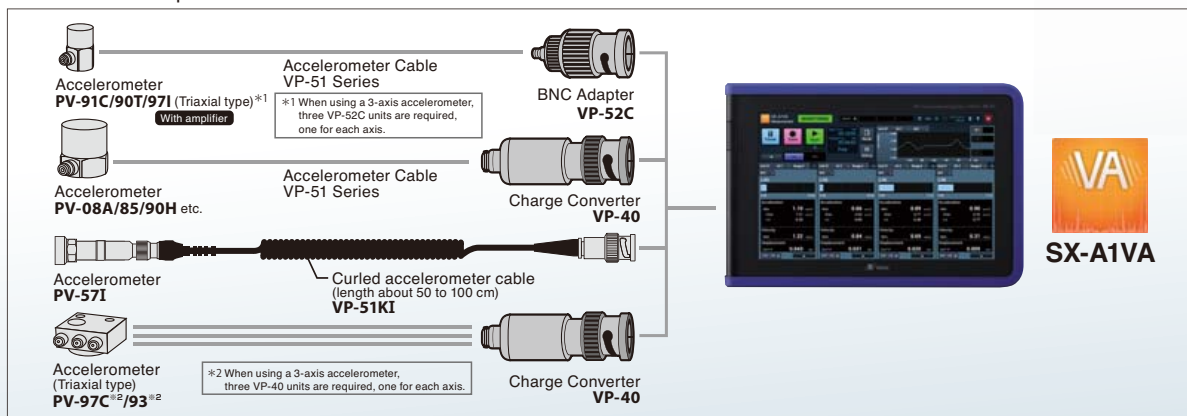

Measurement with relative value evaluation

Trend management (relative value evaluation)

SX-A1VA program can store the data tagged with information of the measurement point and can output the data all together for each measuring object. By using spreadsheet software such as Excel enables trend management of the machinery condition. In order to assess changes in the vibration of rotating machinery or similar which can indicate problems and possible causes, it is necessary to effectively accumulate and manage measurement data. Reference values can then be determined based on these data for example to set caution and danger threshold values.

When a caution threshold is exceeded, monitoring should be strengthened, and when the danger threshold is reached, detailed diagnosis will normally be performed. With many common types of vibration acceleration, values that are about 2 to 3 times above normal are considered caution indicators and a further increase by a factor of 2 to 3 will indicate a danger state. For a given piece of machinery, vibration measurement location, measurement direction, and measurement period are determined, and a graph in which measured values are entered in a time series is created (trend management graph).



Measurement point		Measurement value						
Area	Point	CH1 ACC	CH1 ACC PEAK	CH1 ACC C.F.	CH1 VEL	CH1 DISP	CH1 Evaluation	
Area A	Point A-1							
Machine	Machine 001							
Point	Point A-1							
ACC Unit	m/s ²							
ACC RMS/EQ	RMS							
VEL Unit	mm/s							
VEL RMS/EQ	RMS							
DISP Unit	µm							
DISP RMS/EQ	EQ P-P							
DateTime	Project Name	CH1 ACC	CH1 ACC PEAK	CH1 ACC C.F.	CH1 VEL	CH1 DISP	CH1 Evaluation	
8/4/2017 12:56:05.9	project_0000	0.311622734	2.147816388	6.89236103	0.163034283	25.99104903	Favorable	
9/4/2017 12:57:40.0	project_0001	0.34286847	2.000216633	5.833772449	0.163027499	30.31537769	Favorable	
10/4/2017 12:58:46.2	project_0002	0.354303728	2.493594877	7.038014791	0.220096474	25.5043605	Favorable	
11/4/2017 12:59:53.5	project_0003	0.35794955	2.194137827	6.129740419	0.21329033	21.97810112	Favorable	
12/4/2017 13:01:07.0	project_0004	0.36931514	2.393820994	6.481784072	0.237535333	21.87149994	Favorable	
1/4/2018 13:02:12.9	project_0005	0.379803513	3.077126167	8.101889687	0.214571178	25.71060653	Favorable	
2/4/2018 13:02:49.0	project_0006	0.432314572	3.678793376	8.509528965	0.21192415	23.00814064	Favorable	
3/4/2018 13:03:40.0	project_0007	0.466482974	3.957233521	8.483125308	0.257591261	31.44753308	Favorable	

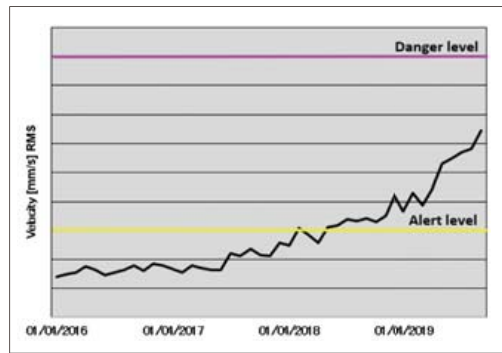

Trend management graph

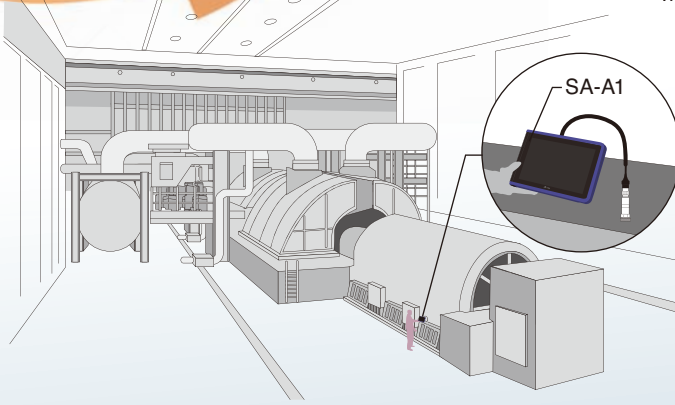

Conceptual drawing of maintenance setup

The SX-A1VA program is used for machine maintenance/inspection. To check for an unbalanced or misaligned condition, velocity and displacement are measured. To check for bearing vibrations, acceleration is measured. Besides maintenance applications, the FFT analyzer function of the SX-A1VA program enables use also for detailed diagnosis.

Constant monitoring and measurement solutions

Constant monitoring of machine vibrations at power stations, plants or other production facilities

Vibration Monitor UG-50

Suitable for continuous monitoring of machine vibrations at production facilities



<Front view>

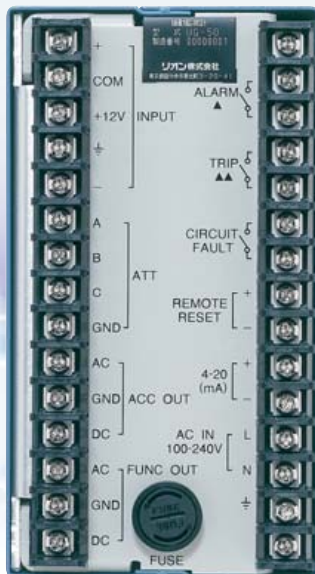

<Rear view>

- Comprises a main circuit and a dedicated acceleration circuit. The main circuit measurement mode can be switched to acceleration, velocity, or displacement for measuring and monitoring vibration quantity values. The dedicated acceleration circuit allows constant acceleration measurement separately from the main circuit.
- For the vibration level in the main circuit, a caution threshold (alarm) and danger threshold (trip) can be set. When the vibration level exceeds this threshold, the output function is triggered (alarm lamp lights up, relay contacts close). The output function (alarm lamp lights up, relay contacts close) can also be triggered when the connection to the input terminals is interrupted.
- Backlit LCD panel allows checking of monitored vibration levels, settings etc.
- Integrated high-pass filters and low-pass filters both for the main circuit and the dedicated acceleration circuit. AC and DC output terminals.

Connection parts for piezoelectric accelerometer and vibration monitor

Measurement setup example

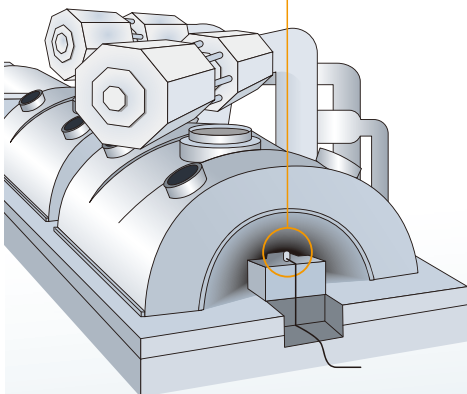
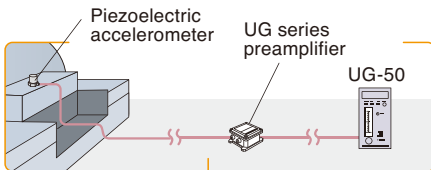

Pre-amplifier UG-20

Charge amplifier to enable transmission cable runs up to 300 meters.

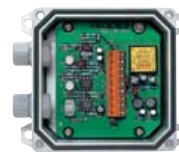

Pre-amplifier UG-21

Relay amplifier for extending preamplifier connection runs up to 400 meters.

Relay Box

Please contact us.

4-20 mA Isolation Unit UG-33

Provides a current output of 4 - 20 mA.
*Factory option

Rack-Mount Panel UG-90

Allows mounting up to five UG-50 units in a JIS standard rack.

User Filter NX-50

Adds a high-pass filter and low-pass filter (one each) to the main circuit.

- HPF: 3.15 Hz to 500 Hz in 1/3 octave band steps (For velocity and displacement, HPF range is 6.3 Hz to 500 Hz)
 - LPF: 50 Hz to 10 Hz in 1/3 octave band steps
- *Factory option

Support for round-the-clock vibration monitoring via USB or Ethernet interface



Vibration Meter Unit UV-15

Vibration meter unit for use with piezoelectric accelerometers, piezoelectric accelerometers with integrated amplifier, and TEDS compliant accelerometers

The Vibration Meter Unit UV-15 supports linked operation of multiple units, providing the capability for up to 16 linked channels. Each unit is equipped with a display that shows various settings as well the measurement value and a bar graph. By including the Interface Unit UV-22 in a linked system, noise and vibration level measurements can be set up and controlled using a computer which also can receive the measured data.

- Backlit LCD and alarm LED indicators
- In a factory or laboratory environment, rack mounting along with other measuring equipment and similar is possible (using the JIS compliant Rack-Mount Base CF-27 [Option]).
- Portability of vibration meter unit allows it to be taken to a measurement location in the field. (Using the BP-17 power supply [Option])



Interface Unit UV-22

Provides a USB and Ethernet interface (one each) for control of the UV-15 from a computer.

A computer running the supplied UV-22Viewer software can be used to make UV-15 settings and check measurement values. Freely selecting a cutoff frequency for the HPF and LPF (user filter*1) is also possible.

In systems with multiple UV-15 units, the master/slave function becomes active for easy operation.

*1 Setting is possible in 1/3 octave band steps over the specified frequency range.

Example for multi-channel vibration measurement system

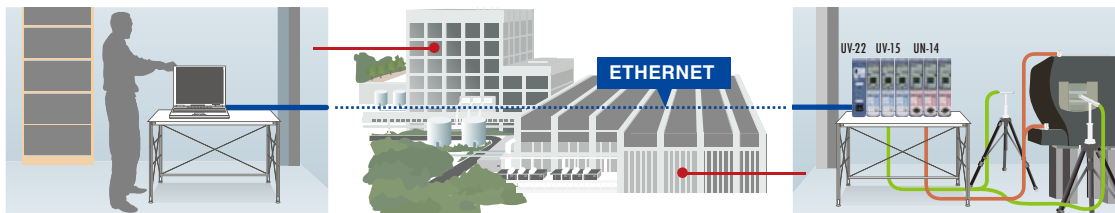

UV-22 Vibration/Noise Monitoring System CAT-UV22-MS

(This software is a product of Catec Inc.)

- Makes it possible to monitor and record time data for sound and vibration measured using the UN-14 and/or UV-15.
- Allows easy setup of multi-point measurements because up to 16 UN-14 and/or UV-15 units can be connected to the UV-22.



Graph display tab (all channels)



Setup tab

Facility diagnosis software

Software for detailed diagnosis

Equipment diagnosis software CAT-EQDIAG

Designed to import vibration data measured with the Rion Vibration Meters VA-12 or VM-82A* and the Data Recorder DA-21* and to display FFT analysis results. This enables detailed machine equipment diagnosis.

*Support planned

Terminology master registration

Register terms to be used in the system.



Unit information setup

During terminology master registration, unit information, operation conditions, and visual appearance can also be registered.



Display trend analysis results

Select multiple data types among registered data to show trends.

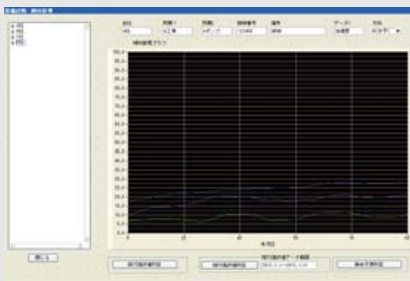

Detailed diagnosis

Select the frequency analysis graph from a list to bring up a waveform screen. Enter specific frequencies at which phenomena occur and use the graph display for detailed diagnosis.

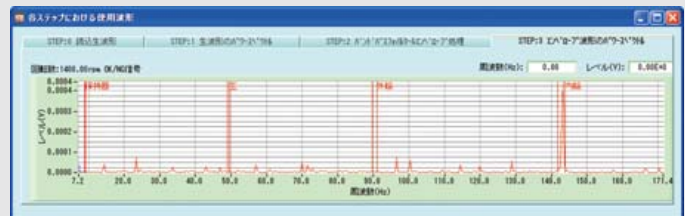

Report

Use the detailed diagnosis data together with Excel report templates to create reports.

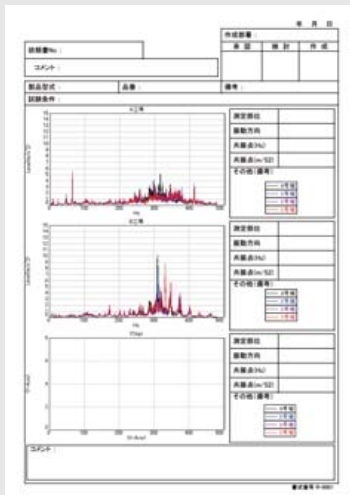

Right-click on the graph to bring up the frequency analysis setup screen.



Other systems

Noise monitoring

Noise monitoring in factories or power plants

Noise Monitoring System SY-117 Series

With microphones installed for example at various noise observation points outdoors, noise levels can be monitored from a central control room. If preset threshold levels are exceeded, an alarm signal is output, and the actual sound at the measurement point can also be monitored via a speaker. The system comprises sound level meters and a separate external control panel. The use of preamplifiers allows extending the microphone cable runs so that microphones can be installed at remote locations.

System diagram

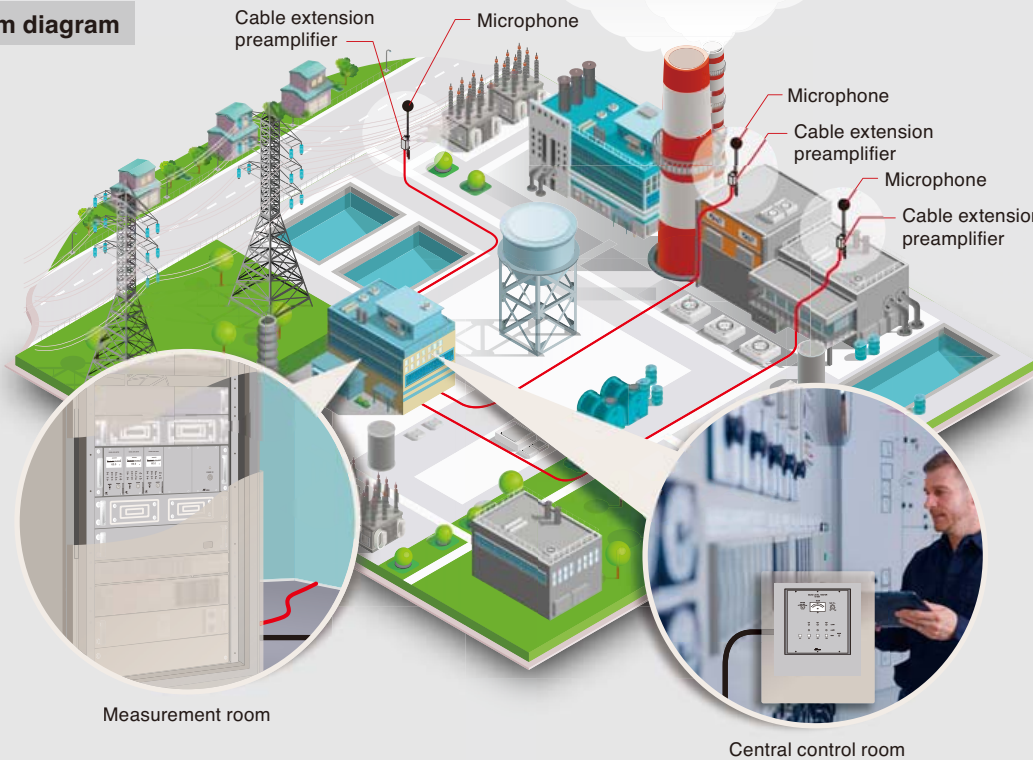

Software for RIONOTE Multifunction Measurement System

Pass/fail evaluation of noise, vibrations etc. generated by production or inspection lines

Judgement Program (Pass/Fail Evaluation) SX-A1CMP

Allows the definition of threshold areas for FFT analysis results to determine pass/fail.



Noise or vibration evaluation to assess causes of resonance phenomena related to revolution speed changes

Order Tracking Program CAT-SAA1-ORDTRK

(This software is a product of Catec Inc.)

Automatic analysis based on recorded revolution data and noise/vibration waveform data



Product Information

Broad and versatile lineup makes it possible to choose the optimum product for any given application.

Piezoelectric Accelerometers

Piezoelectric Accelerometers

With built-in amplifier	General type	Compact	Waterproof insulation type	Triaxial
-------------------------	--------------	---------	----------------------------	----------

Photo



Model	PV-91C	PV-85	PV-90B	PV-10B	PV-97
Outline /purpose	Compact, lightweight, High temperature	Standard type for general applications	For lightweight structures	Integrated amplifier, protection grade 8 submersible type, 2 atm	Triaxial, 200 °C
Mass g	1.8	23	1.2	120	10
Charge sensitivity pC/ (m/s ²)*1	—	6.42	0.18	—	0.29
Voltage sensitivity mV/ (m/s ²)*1	1	—	—	5.1	—
Vibration frequency range (±1 dB) Hz*2	1 to 20 000 (10 %)*3	1 to 7 000	1 to 25 000	3 to 8 000	1 to 10 000 (Z) 1 to 5 000 (X·Y)(±10 %)
Temperature range for use / °C	-50 to +170	-50 to +160	-50 to +160	-20 to +100	-50 to +200
Dimensions mm	7 (Hex) × 12.5 (H)	17 (Hex) × 18.5 (H)	6 (Hex) × 10 (H)	23 (φ) × 40 (H)	13 (H) × 13 (W) × 13 (D)

*1 Representative value; actual value is noted on calibration sheet supplied with accelerometer.
*2 Representative value when mounted on flat surface according to standard mounting method.
*3 1 to 2 Hz (±15 %) at 150 to 170 degrees.

Charge converters with CCLD support

Charge Converter VP-42

(Compact relay type)



Charge Converter VP-40

(For direct connection to BNC input)



Specifications

Model	VP-40	VP-42
Gain	1 mV/pC ±2.5 % (80 Hz)	1 mV/pC ±2.5 % (80 Hz)
Frequency range	1 Hz to 30 kHz (±5 %)	1 Hz to 30 kHz (±5 %)
Drive current	2 mA to 4 mA	2 mA to 4 mA
Dimensions (mm)	φ14.5 × 45	φ7 × 27.7

Simulator tool for efficient teaching of equipment diagnosis techniques

Micromaster

- Rotational speed: 100 to 3000 rpm
- Simulated phenomena
 - ① Unbalance
 - ② Bearing race damage (inner or outer ring)



Minimaster

- Rotational speed: 100 to 1400 rpm
- Simulated phenomena
 - ① Unbalance
 - ② Misalignment
 - ③ Bolt loosening (backlash)
 - ④ Bearing fault
 - ⑤ Gear fault (tooth width 1/2 wear)



JCSS 0197

RIION Co., Ltd. is recognized by the JCSS which uses ISO/IEC 17025 (JIS Q 17025) as an accreditation standard and bases its accreditation scheme on ISO/IEC 17011. JCSS is operated by the accreditation body (IA Japan) which is a signatory to the Asia Pacific Laboratory Accreditation Cooperation (APLAC) as well as the International Laboratory Accreditation Cooperation (ILAC). The Quality Assurance Section of RIION Co., Ltd. is an international MRA compliant JCSS operator with the accreditation number JCSS 0197.

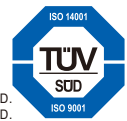

ISO 14001 RIION CO., LTD.
ISO 9 0 0 1 RIION CO., LTD.

* Windows is a trademark of Microsoft Corporation. * Specifications subject to change without notice.

Distributed by:

 **RIION CO., LTD.**
<https://riion-sv.com/>

3-20-41, Higashimotomachi, Kokubunji, Tokyo 185-8533, Japan
Tel: +81-42-359-7888 Fax: +81-42-359-7442