

Hand-Arm Vibration Measurement System

A machinery safety directive was enacted by the EU in 2002, whose objective and main targets are shown below

Purpose:	Obligate employers to reduce the risk of injury in persons using hand-held power tools.
Main requirements:	Require employers to establish indicative values and limit values. If indicative values are exceeded, provide information to machinery operators about risk reduction, and carry out suitable health checks.

In order for employers to assess the vibration exposure of operators, data regarding the vibration levels of hand-held power tools as well as about usage time etc. are required. Manufacturers of hand-held power tools must provide vibration ratings and indications that allow employers to fulfill their obligations. A measurement setup for the evaluation of human exposure to hand-transmitted vibration is described in ISO 5349-1. Measurement methods are specified in ISO 8662-1 and ISO 5349-2. The current system complies with these standards. Because frequency analysis is carried out at the same time, the results are also useful for devising vibration countermeasures.

System Diagram

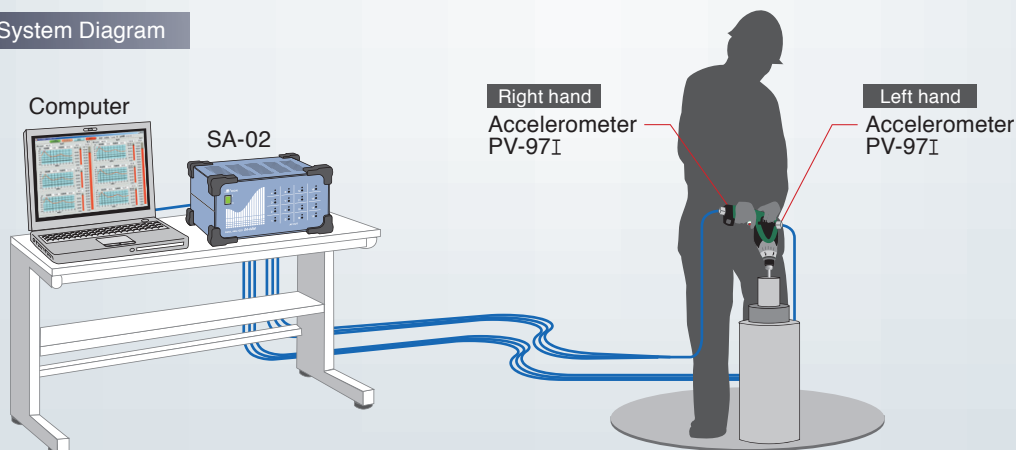

Equipment configuration

Product	Model	Quantity
Multi-Channel Signal Analyzer	SA-02M (8ch)	1
Computer for SA-02		1
Hand-arm Vibration Measurement Software	CAT-SA02-HT	1
Piezoelectric Accelerometer (Triaxial)	PV-97I	2
BNC adapter	VP-52C	6
BNC link connector	VP-54C	6*1
BNC-BNC coaxial cable	EC-90 series	6*1

*1 The PV-97I is supplied with a 3-meter cable. These extension parts are required only if longer cable runs are necessary.

Measurement result examples

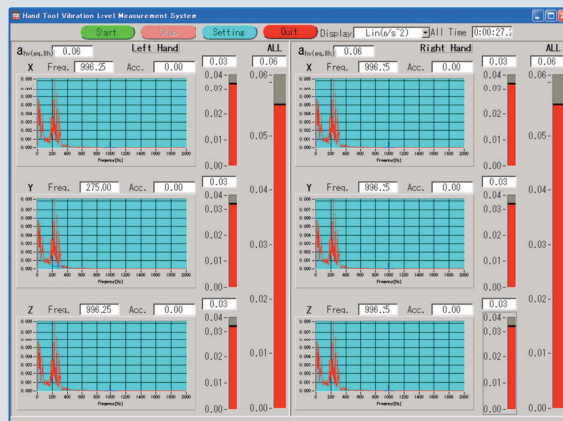

Measurement screen

Application examples

Hand-held power tools such as chain saws, bush cutters, sanders, grinders, rock drills, pavement breakers, etc.

Applicable standards, reference material

- ISO 8041 Human response to vibration Measuring instrumentation
- ISO 5349-1 Mechanical vibration - Measurement and evaluation of human exposure to hand-transmitted vibration - Part 1: General requirements
- ISO 5349-2 Mechanical vibration - Measurement and evaluation of human exposure to hand-transmitted vibration - Part 2: Practical guidance for measurement at the workplace
- ISO 8662-1 Hand-held portable power tools - Measurement of vibrations at the handle - Part 1~Part14

Supplementary information: Measurement method features

- ① Triaxial measurement
- ② Hand-arm frequency correction coefficient W_h is used.
- ③ Evaluation quantity: Vibration total value a_v (m/s^2)
This value is determined by the vector sum of vibration values for each axis.
- ④ Measurement time: At least 1 minute is desirable.
- ⑤ Accelerometer attachment position: Specified separately in standards for respective product category.

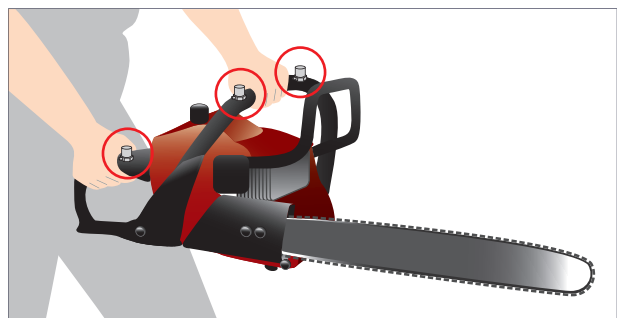
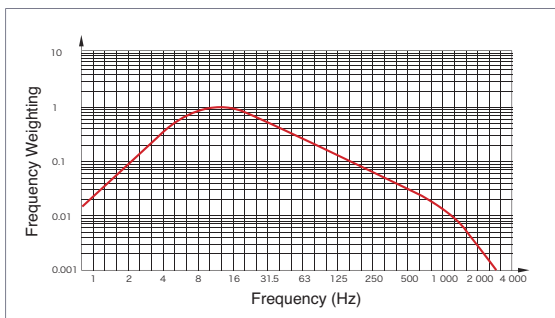

Example of accelerometer attachment positions (chain saw)



RION Co., Ltd. is recognized by the JCSS which uses ISO/IEC 17025 (JIS Q 17025) as an accreditation standard and bases its accreditation scheme on ISO/IEC 17011. JCSS is operated by the accreditation body (IA Japan) which is a signatory to the Asia Pacific Laboratory Accreditation Cooperation (APLAC) as well as the International Laboratory Accreditation Cooperation (ILAC). The Quality Assurance Section of RION Co., Ltd. is an international MRA compliant JCSS operator with the accreditation number JCSS 0197.

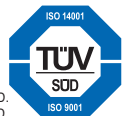

ISO 14001 RION CO., LTD.
ISO 9001 RION CO., LTD.

* Specifications subject to change without notice.

Distributed by:

 **RION CO., LTD.**
<https://rion-sv.com/>

3-20-41, Higashimotomachi, Kokubunji, Tokyo 185-8533, Japan
Tel: +81-42-359-7888 Fax: +81-42-359-7442